



Loving music

Statement TT1

Tangential tonearm

User Manual



Made in Germany

Hi-Fi Components **clearaudio electronic** GmbH

Spardorfer Str. 150 • D-91054 Erlangen • Tel. +49(0) 1805/059595 • FAX +49(0) 09131/51683
www.clearaudio.de • www.analogshop.de • info@clearaudio.de / copyright clearaudio© 2007



Loving music

Statement TT 1

User manual

Dear audio enthusiast,

Thank you for your decision to purchase the patented *Statement TT 1 tangential* tonearm from **clearaudio**. This tonearm is manufactured to the highest degree of tolerance and quality.

Please take a moment to read this owner's manual to ensure correct set up, to avoid any possible damage and to learn how proper care of your clearaudio Statement TT 1 tangential tonearm, which will give you many years of musical enjoyment and pleasure.

This section must be read before any connection or setup is made, so that the warranty will not be void.

Warnings

- Do not expose the equipment to rain or moisture.
- Do not remove the cover from the equipment.
- Do not insert anything into the equipment through the ventilation holes.
- Do not handle the mains lead with wet hands.
- No naked flame sources, such as lighted candles, should be placed on the equipment.

CE-MARKING



COPYRIGHT

Recording and playback of any material may require consent. For further information refer to the following:

- Copyright Act 1956
- Dramatic and Musical Performers Act 1958
- Performers Protection Acts 1963 and 1972

Any subsequent statutory enactments and orders

Contents

1. Package contents	4
2. Package overview	5
3. Front and back view of assembled TT 1 tonearm	6
4. Assembly and operation	7 - 8
5. Statement TT 1 tonearm mounting on Statement	9 - 12
6. Cartridge pre-adjustment / adjustment	13 - 14
7. Transportation advice	15
8. Service - information	15
9. Warranty	16
10. Technical data	17

1. Package contents

The **clearaudio** *Statement TT 1 Tangential* tonearm is delivered in specially designed packaging to ensure its safe transport. Please check the contents as shown in picture below and in the list at the bottom of this page:



1	Tonearm chassis	2	Armwand, incl. cable
3	Round mounting base (2x)	4	Installation gauge for the tonearm base
5	Bag of mexkey wrenches	6	Main counter weight
7	Exchangeable counter weight 10g (e.g. GOLDRING) and 5g (e.g. for TITANIUM)	8	Precision glastube for bearing device/ carriage
9	Hex key screws: to mount tonearm on 2x round bases	10	2x big hex key bolts
11	White pair of gloves	12	Quartz tube assembly kit
13	Installation gauge for cartridges	14	Cartridge/ Headshell mounting screws
15	Instruction manual (not shown)		

2. Package view

The Statement TT 1 is packed in a special foam packing and comes almost completely assembled.



Picture 1: Package view

Tonearm chassis, not including the armwand.

The armwand and the glastube are packed separately and need to be installed.



Picture 2: Armwand and glastube

The accessories, tools etc. are packed as well separately.



3. Clearaudio STATEMENT TT1/ tangential tonearm

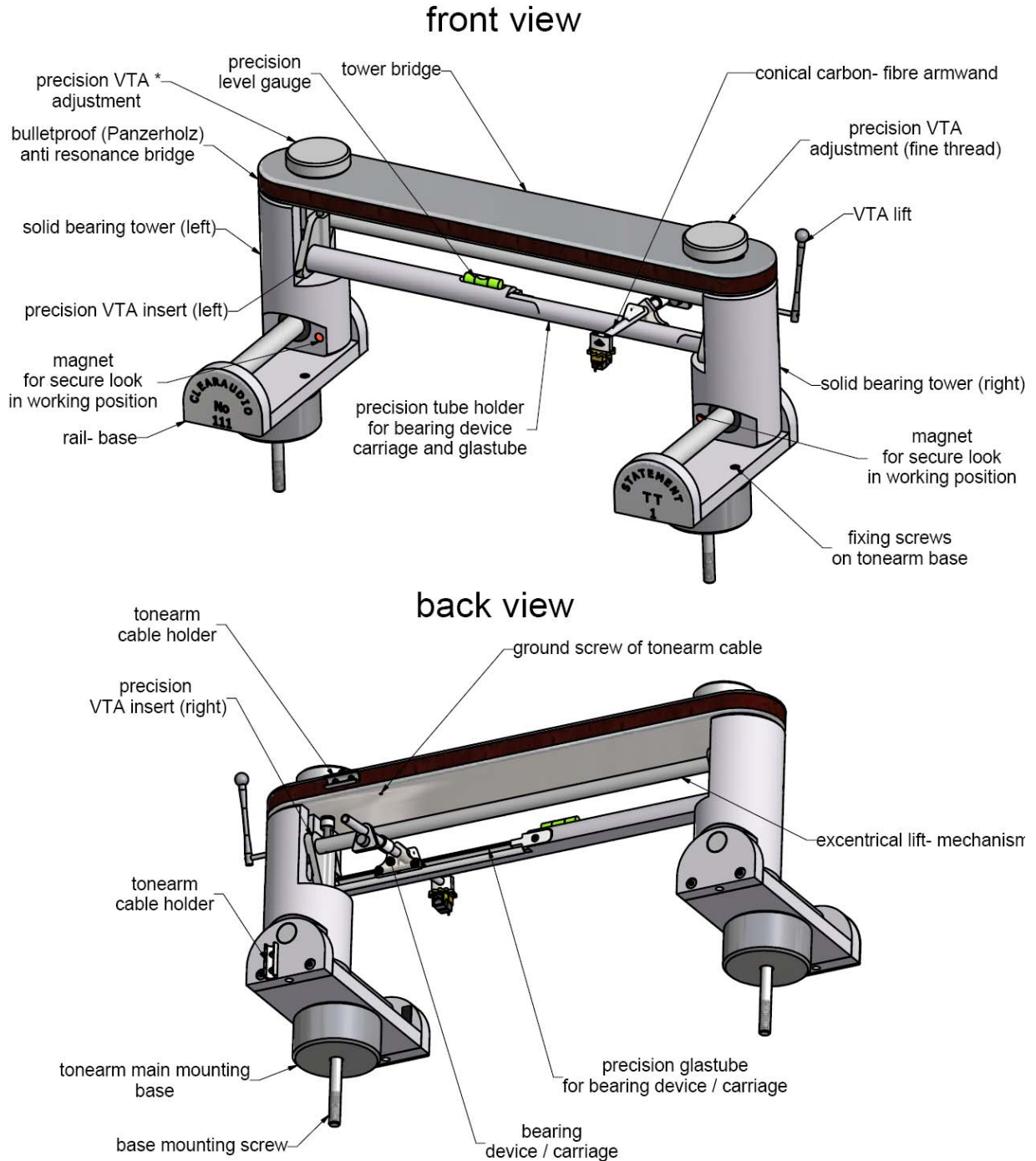

technical data: dimensions: width 521mm heigt 211mm depth 199mm
 weight: 8,6 kg
 construction principle: high precision mechanical
 ultra low friction, linear tracking design

* VTA = Vertical- Tracking- Angle

Picture 3: Front and back view

4. Preassembly and operation

After checking the package contents as described, place the parts on a clean, safe and flat surface to get ready for the setup. The assembly and setup is fairly simple and straight forward as many parts have been already preassembled at the factory. Please use the white gloves provided, to prevent scratches and/or fingerprints during assembly.

First you start to assembly the 2 main tonearm stainless steel round base (stainless steel cylinders) on to the Statement turntable. Please note, you might have to take off the previous cylinders, please use only the provided one's, as they are matched in height for the TT1 tonearm.

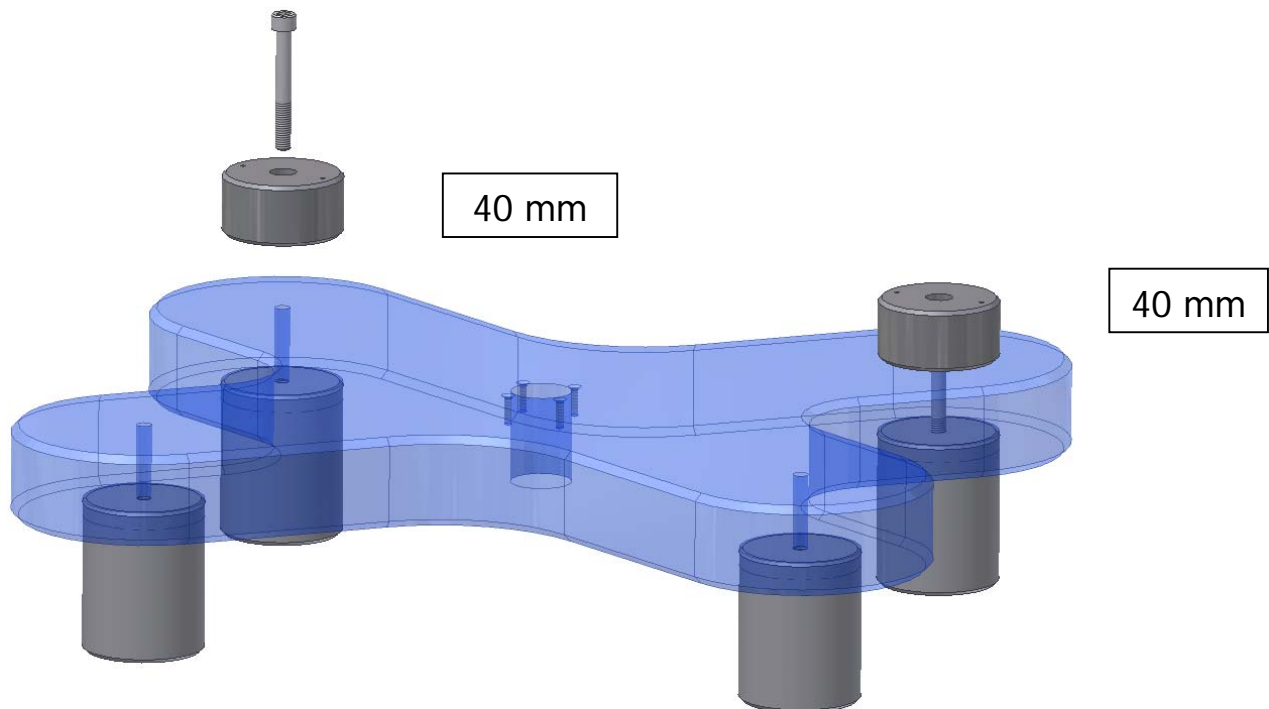

Picture 4: Putting the stainless steel round base onto the Statement turntable

Do not tighten the cylinders completely, you should be still able to turn them.

Now place the installation gauge (4) for the tonearm base on top of the two cylinders (3) while all four pins on the bottom of the installation gauge, must fit into the threats machined into the cylinders. You might have to turn the cylinders for correnty aligning.

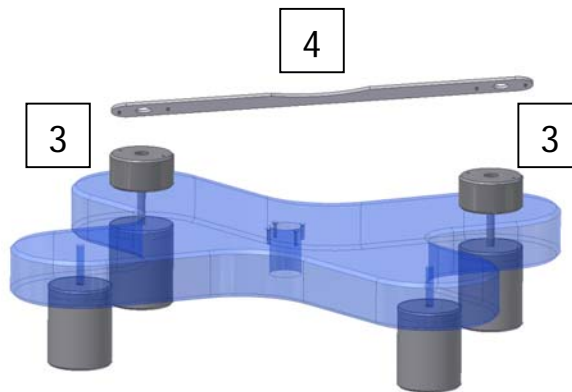

Picture 5: Placing the installation gauge

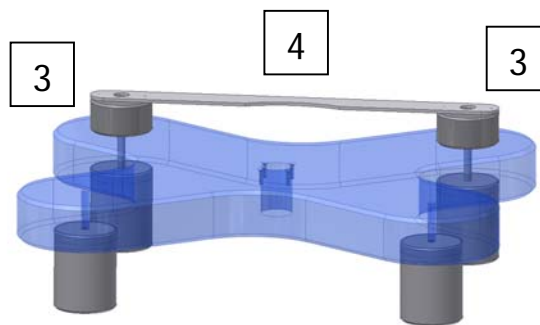

Picture 6: Placing the installation gauge

Tighten the 2 bolts, with the provided hex key, while holding (pressing) the gauge down.
Attention: any misalignment will lead to a problem to place the TT1 tonearm later !

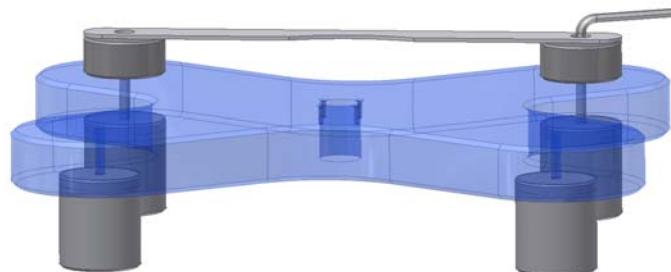

Picture 7: Tighten the gauge

5. Statement TT1 tonearm mounting on Statement

Now you can place the tonearm chassis on top of the 2 cylinders. Take it carefully with one hand at the top cover (tower bridge), so that the sliding bars are not moving. While holding it in place, over the 4 machined threads, start inserting the provided (4) hex key screws and tighten them.

Please note: Always hold the tonearm in place while fixing the 4 screws!

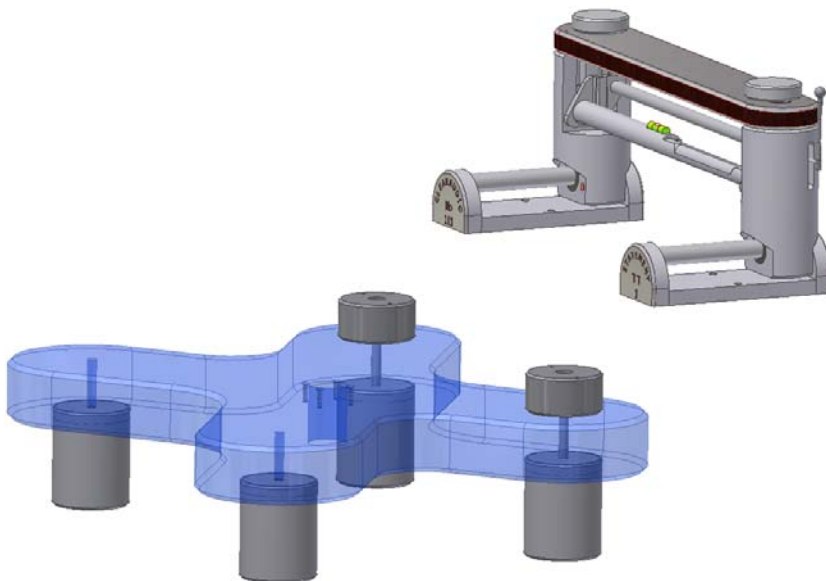

Picture 8: Placing the tonearm chassis on the top

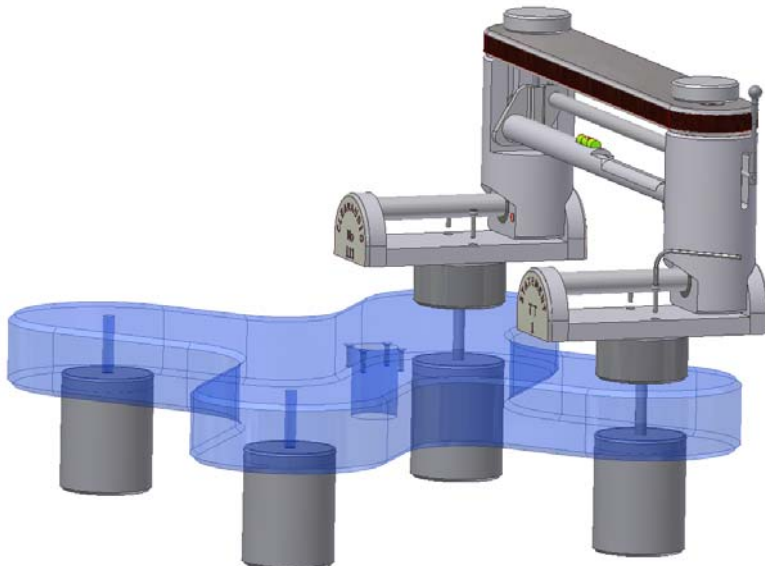

Picture 9: Tighten the screw of the tonearm

Tighten the screws, one by one, gently but firm.

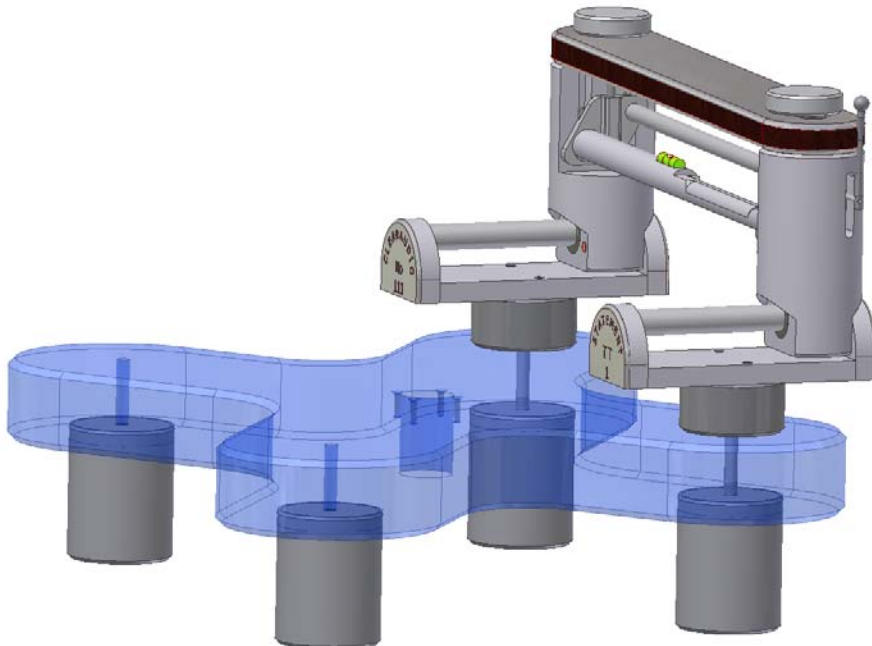

Picture 10: Finished view of the tonearm installation

Please note:

You might have to readjust the leveling of the Statement turntable, when finished with the complete setup.

The following steps must be done with a lot of caution !

Take the precision glastube and the armwand / carriage assembly and slide it into the glastube. The headshell mounting area is facing into the direction that the cut out gap of the tube in the back.

Please note: There is no tension force allowed to the very fine/ thin tonearm cable. Damage can occur !



Picture 11: Precision glastube

Place the glastube assembly kit as described:

first the piece with the round rubber at the right end of the glastube in position (inserting), then the round stopper into the left side of the glastube.

Now slide the glastube into the machined precision tube holder (at the back of the TT1 tonearm) and place it into the buffer by pushing it into the left rubber ring

Attention: Put the glastube flat into the cut out, then push it leftwards! Damage can occur !



Picture 12: Placing the glstube into the precision tube holder



Picture 13: Placing the tonearm cable into the assembled tonearm

Now you just have to place the tonearm cable into the assembled tonearm cable holder at the back of the tonearm. Please make sure that the tonearm cable makes a loop, so that there is enough freedom for the cable, while sliding the tonearm back and forward.

Please note: You might want to fix the tonearm cable with a tape to the tower bridge.



Picture 14: Fixing the tonearm with a tape



Picture 15: Tight the screw gently!

Tight the screw gently!

The tonearm cable is equipped with a ground washer. Take the attached ground screw, below the tower bridge and attached the ground washer, while screwing it in the associated thread.

6. Cartridge pre-adjustments

First mount the cartridge into the headshell, with the provided two headshell screws.

Place a record on the platter in order to install the height and VTA.

Turn the two knobs of precision VTA adjustment (wheels) on top of the tonearm till the armwandaxis is parallel to the Record surface.

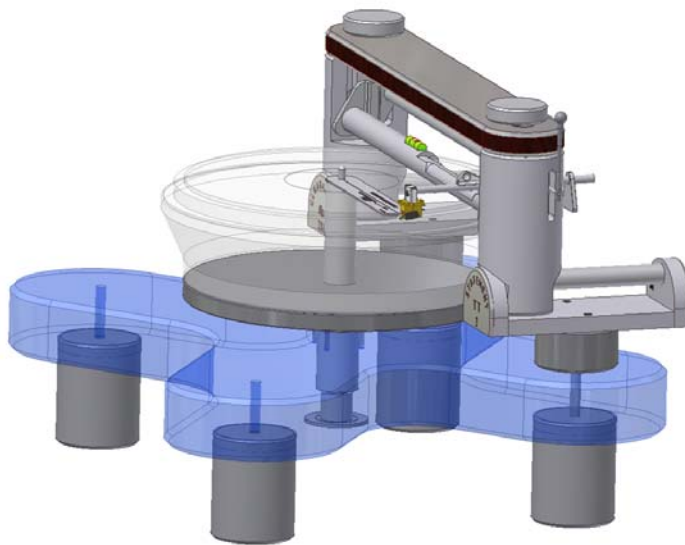

Picture 16: Cartridge pre-adjustments

Cartridge adjustment

The correct tangential adjustment is mandatory.

For the correct adjustment use the cartridge alignment gauge, which needs to be placed on the spindle first.

The diamond tip of the cartridge must be always aligned in the blackline (groove) of the gauge.

This fine adjustment can be realised by moving the armwand back or forward.

Simply lock or unlock the screw on the bottom of the carriage.



Picture 17: Cartridge adjustment

Weight adjustment :

Slide the appropriate exchangeable counter weight over the back of the armwand tube and adjust the correct tracking force.

Please hold the armwand carefully in order not to put too much force to the bearings.

For the best results we recommend the use of the clearaudio weight watcher stylus force gauge.

- (e.g. 10 g for Goldfinger or 5 g for Titanium)



Picture 18: Weight adjustment



Loving music

Statement TT 1

User Manual

7. Transportation advice

If any transportation of the *Statement TT1* tonearm should be necessary, please always use original packing material. Otherwise serious damage could occur!

The armwand needs to be built out, to avoid any possible damage as well

If the Statement TT1 tonearm is not in use for a longer period, please cover the tonearm in order to prevent it from dust.

You can clean the glastube with pure alcohol.

Please make sure that the precision dry ball bearings should not be touched, cleaned or lubricated in any aspect. Please clean only the glastube !

WARNING:

Never insert the oil into the precision bearing! This will result in damage of bearing!

8. Service - information

If any service or repair of a **clearaudio** product is necessary, please contact your dealer - distributor or contact **clearaudio** directly. We will inform you about your nearest service location.

PLEASE RETAIN ALL ORIGINAL PACKAGING. You will need it if this unit has to be transported and/or shipped. Any further questions you may have about this product should be directed to the distributor or directly to **clearaudio** :

clearaudio electronic GmbH

Spardorfer Str 150
91054 Erlangen
Germany

Tel/Phone: +49-(0)1805/059595

www.clearaudio.de

www.analogshop.de

info@clearaudio.de



Loving music

Statement TT 1

User Manual

9. Warranty information

To achieve the full **clearaudio** warranty, it is necessary that you fill out and send the corresponding part of the warranty registration card back to clearaudio, within two weeks after purchase. Only if the product is returned in its original packing **clearaudio** can provide the warranty of 10 years.

ENGLISH

WARRANTY

For warranty information, contact your local clearaudio distributor.

RETAIN YOUR PURCHASE RECEIPT

Your purchase receipt is your permanent record of a valuable purchase.

It should be kept in a safe place to be referred to as necessary for insurance purposes or when corresponding with clearaudio.

IMPORTANT

When seeking warranty service, it is the responsibility of the consumer to establish proof and date of purchase. Your purchase receipt or invoice is adequate for such proof.

FOR U.K. ONLY

This undertaking is in addition to a consumer's statutory rights and does not affect those rights in any way.

FRANÇAIS

GARANTIE

Pour des informations sur la garantie, contacter le distributeur local clearaudio.

CONSERVER L'ATTESTATION D'ACHAT

L'attestation d'achat est la preuve permanente d'un achat de valeur. La conserver en lieu sûr pour s'y reporter aux fins d'obtention d'une couverture d'assurance ou dans le cadre de correspondances avec clearaudio.

IMPORTANT

Pour l'obtention d'un service couvert par la garantie, il incombe au client d'établir la preuve de l'achat et d'en corroborer la date. Le reçu ou la facture constituent des preuves suffisantes.

DEUTSCH

GARANTIE

Bei Garantiefragen wenden Sie sich bitte zunächst an Ihren clearaudio-Händler.

Heben Sie Ihren Kaufbeleg gut auf.

WICHTIG!

Die Angaben auf Ihrer Quittung erlauben uns die Identifizierung Ihres Gerätes und belegen mit dem Kaufdatum die Dauer Ihrer Garantie-Ansprüche.

Für Serviceleistungen benötigen wir stets die Gerätenummer.

Diese finden Sie auf dem Typenschild auf der Rückseite des Gerätes, oder auch in der beigelegten Garantie-Registrierkarte.

NEDERLANDS

GARANTIE

Voor inlichtingen omtrent garantie dient u zich tot uw plaatselijke clearaudio.

UW KWITANTIE, KASSABON E.D. BEWAREN

Uw kwitantie, kassabon e.d. vormen uw bewijs van aankoop van een waardevol artikel en dienen op een veilige plaats bewaard te worden voor evt. verwijzing bijv. in verband met verzekering of bij correspondentie met clearaudio.

BELANGRIJK

Bij een evt. beroep op de garantie is het de verantwoordelijkheid van de consument een gedateerd bewijs van aankoop te tonen. Uw kassabon of factuur zijn voldoende bewijs.

ITALIANO

GARANZIA

L'apparecchio è coperto da una garanzia di buon funzionamento della durata di un anno, o del periodo previsto dalla legge, a partire dalla data di acquisto comprovata da un documento attestante il nominativo del Rivenditore e la data di vendita. La garanzia sarà prestata con la sostituzione o la riparazione gratuita delle parti difettose.

Non sono coperti da garanzia difetti derivanti da uso improprio, errata installazione, manutenzione effettuata da personale non autorizzato o, comunque, da circostanze che non possano riferirsi a difetti di funzionamento dell'apparecchio. Sono inoltre esclusi dalla garanzia gli interventi inerenti l'installazione e l'allacciamento agli impianti di alimentazione.

Gli apparecchi verranno riparati presso i nostri Centri di Assistenza Autorizzati. Le spese ed i rischi di trasporto sono a carico del cliente. La casa costruttrice declina ogni responsabilità per danni diretti o indiretti provocati dalla inosservanza delle prescrizioni di installazione, uso e manutenzione dettagliate nel presente manuale o per guasti dovuti ad uso continuato a fini professionali.

ESPAÑOL

GARANTIA

Para obtener información acerca de la garantía póngase en contacto con su distribuidor clearaudio.

GUARDE SU RECIBO DE COMPRA

Su recibo de compra es su prueba permanente de haber adquirido un aparato de valor. Este recibo deberá guardarlo en un lugar seguro y utilizarlo como referencia cuando tenga que hacer uso del seguro o se ponga en contacto con clearaudio.

IMPORTANTE

Cuando solicite el servicio otorgado por la garantía el usuario tiene la responsabilidad de demostrar cuándo efectuó la compra. En este caso, su recibo de compra será la prueba apropiada.



Loving music

Statement TT 1

User Manual

10. Technical data

Construction principle:	High precision mechanical tangential extremely low friction 2 point linear tracking design (Patent No. PA 1020060529138).
Total weight:	8,6 kg, incl. armwand
Dimensions (H x H x D in inch):	approx. 521 x 211 x 199
Dimensions (H x H x D in mm):	approx. 20,51 x 8,31 x 7,83
Warranty:	10 years* (see chapter 9)

Stand: October 07